

Restaurering av glassmalerier



Elisabeth Voss Sinnerud, glassverkstedet, Nidaros Domkirkes Restaureringsarbeider.



Kalvskinngata 6

- Seks par med glassmalerier i trappeoppgangen.
- Ett mindre ovalt vindu nederst i trappa, uten naturlig belysning bak.



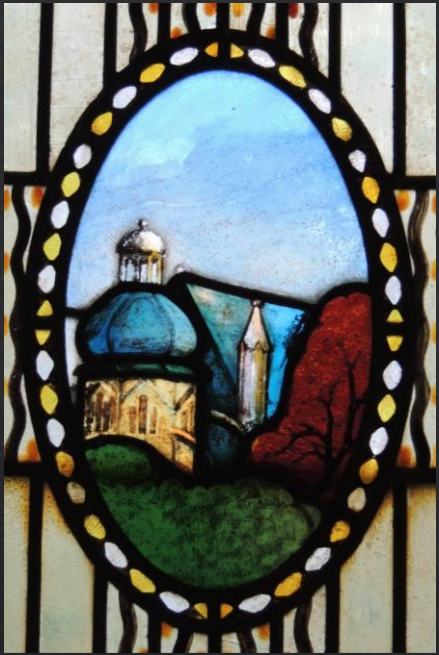

Trondheimsmotiver





Tilstandsrapport



Hva ser vi etter?

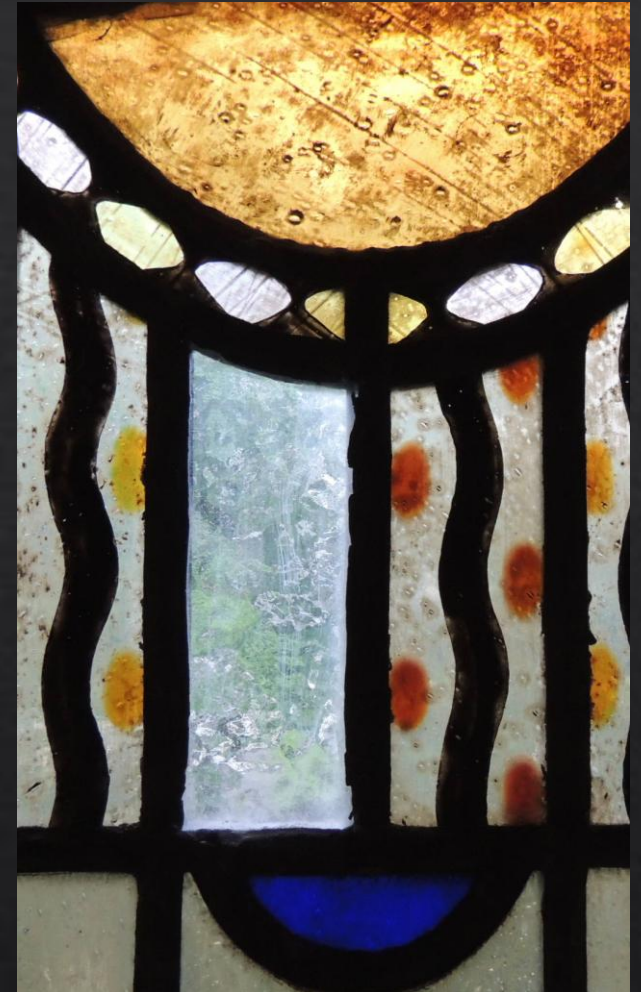
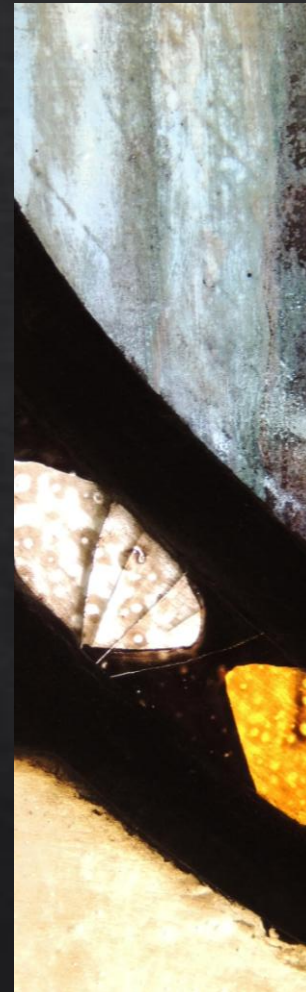
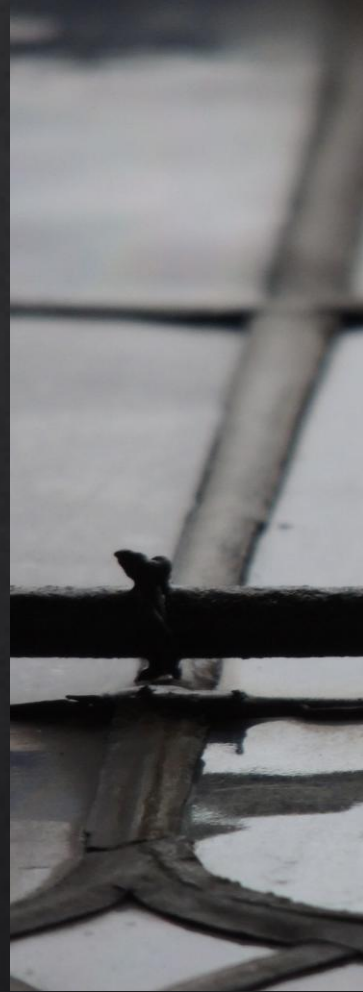

Tilstand på bly, stormstag, glassbrudd, tidligere restaureringer/manglende originalglass

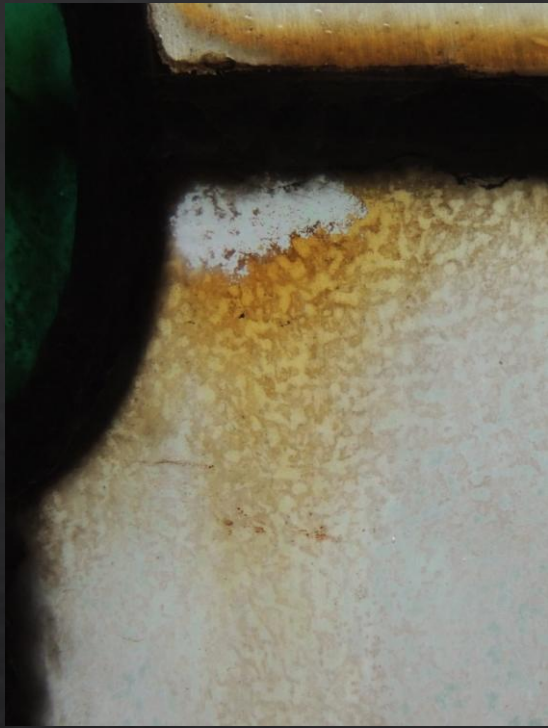

Misfarging etter rust, deformeringer, avskalling av maling, tilstanden på glassoverflaten.

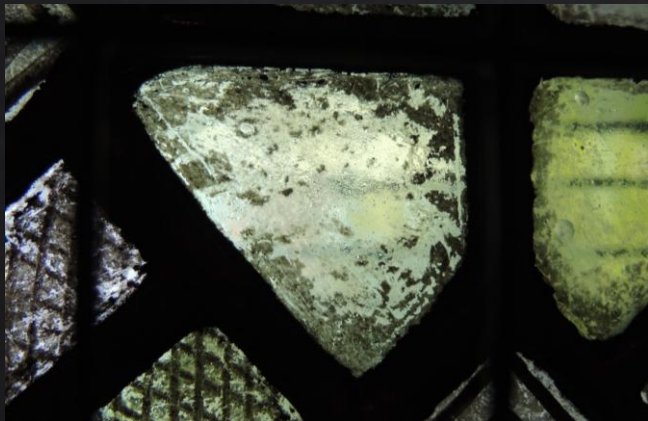



Eksempel på praktisk utføring av restaurering av et glassmaleri



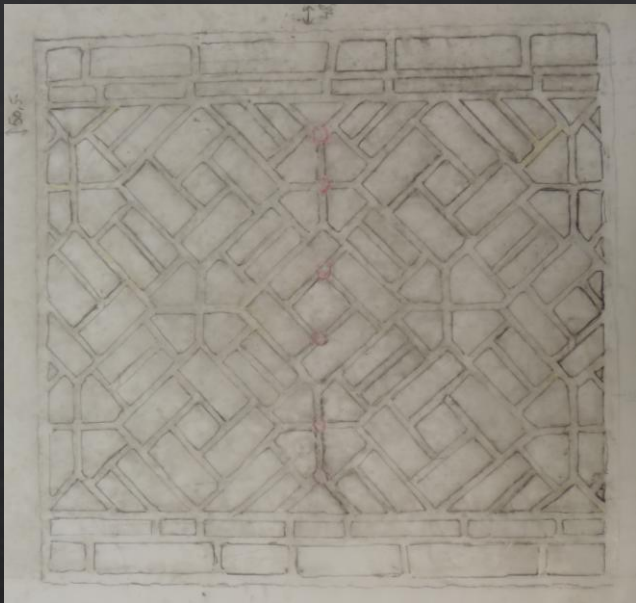

- Arbeidstegning
- Demontering
- Fjerning av kitt
- Rengjøring
- Maling
- Silverstain

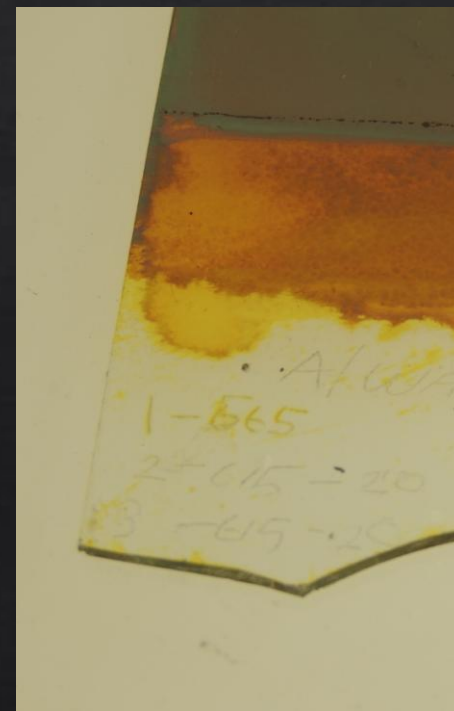

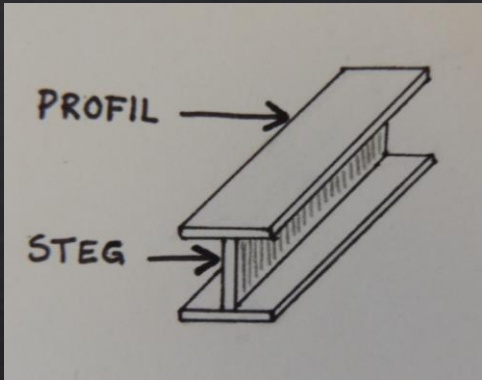

- Rekonstruksjon av glassmaleriet med nytt bly.
- Lodding
- Kitting
- Remontering





Materialer

